

MODEL M OVERVIEW

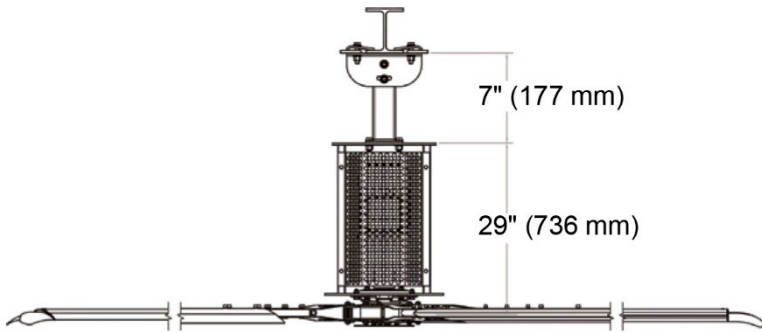

Project Number:

Project Name:

Customer:

Product Information

Fan: M Series

Blade Diameter: 8 ft – 24 ft

Material: Corrosion-resistant anodized blades aluminum hub and blade support system.

TAGS	QTY	MODEL	HP	RPM	ELECTRICAL	STATIC PRESSURE	AIRFLOW

STANDARD FEATURES

- **Near Ground Effect Air Flow:** The powerful, low speed motor ensures powerful air movement, up to 24 feet from the unit. All the way to floor level.
 - 1.5 HP motor circulates air 8 FT - 20 FT
 - 2 HP motor circulates air up to 24 FT
- **Quiet operation:** <55 Dba. Operation.
- **High-efficiency variable frequency drive (VFD):** Power is dependent on blade size.
- **Efficient NACA Airfoil Blades:** Reduce drag while producing more airflow.
- **Touch-screen Control Panel:** Forward/off/reverse switch, self-diagnostics, and 4-digit pass code protection. Comes with a 25 FT power cable, pre-wired to the fan motor. Patented facility fire system compatibility
- **Certification:** UL 507 Certification.
- **Safety Features to Ensure Worry-Free Operation:** Fused disconnect, steel hub, aircraft-grade safety cable(s), and guy wires.
- **Customizable features to meet your buildings' needs:** blades, plates, controls, etc. Can be customized to meet customers needs.to fit each customer's needs.

NOTE: Romla Fans is committed to product improvement and retains the right to change specifications and dimensions at will without prior notification.