

MODEL RWD OVERVIEW

Project Number:

Project Name:

Customer:

STANDARD FEATURES:

- 19 ga. G-90 galvanized steel frame
- Weather stripping in the frame construction for additional strength to the frame.
- Ample 9/32" x 1/2" mounting holes.
- 26-gauge aluminum blades
- Tie-rods on blades for uniform opening / closing.
- Felt seal on leading edge for quiet closing.
- Blades move freely for full opening and closing.
- Flanged blade ends for more effective weather protection.
- Stainless steel bushings & pivot pins.
- Maximum velocity is 2600 FPM with standard propeller fan.

NOTES

1. This damper is for exhaust only. do not motorize as air supply.
2. This damper is not to be used with vane-axial or tube axial fans.

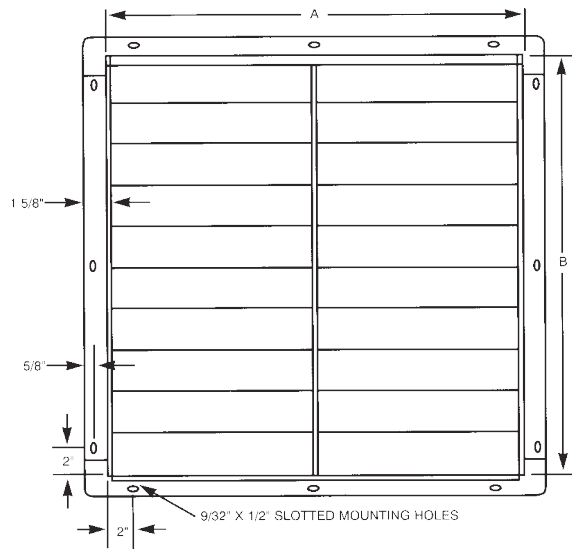

FRONT VIEW

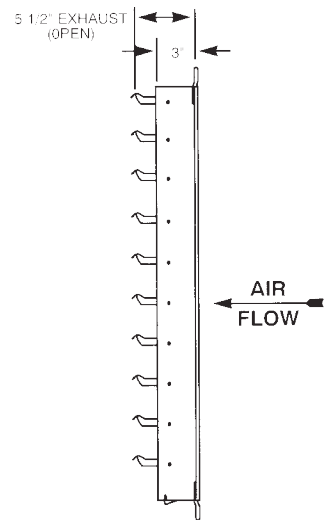

SIDE VIEW

QTY	MODEL	OPENING A	OPENING B	MOTORIZED	VOLT.	MARKING

NOTE: Romla Fans is committed to product improvement and retains the right to change specifications and dimensions at will without prior notification.