

MODEL TB OVERVIEW

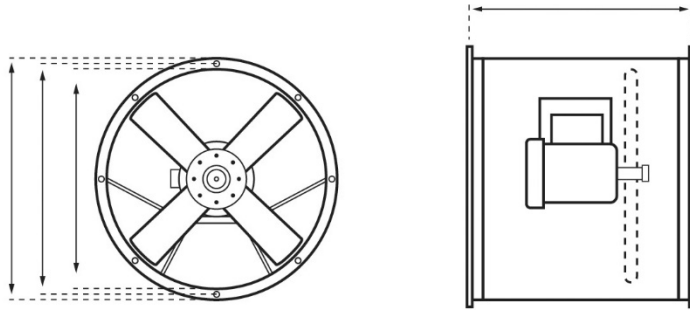

Project Number:
Project Name:
Customer:
Date:

Product Information

Fan: T Series
Drive: Belt Drive
Motor(s):

FAN SIZE	DIMENSIONS (INCHES)						APPROX. WT. (lbs.)
	A	B	C	D	L	H	
24	27 3/16	25 7/8	24	26	22	7/16	210
30	34 3/16	32 3/8	30	29	24	7/16	263
36	40 3/16	38 3/8	36	33	26	7/16	361
42	46 3/16	44 3/8	42	37	32	7/16	450
48	52 3/16	50 3/8	48	40	36	7/16	625
54	58 3/16	56 3/8	54	47	37 1/2	7/16	675
60	64 3/16	62 3/8	60	50	40	7/16	1550

STANDARD FEATURES

- **Superior Strength Housing:** Heavy gauge all-welded housing with steel angle end flange rings.
- **Variable Pitch Drives to 7-1/2 HP:** Adjustable for systems RPM. Belts sized for 165% driven HP.
- **Industrial Duty Motor for Years of Trouble Free-Operation:** Totally enclosed fan cooled (TEFC) motor.
- **Self-aligning Pillow Block Bearings**
- **Adjustable motor base:** Provided for tightening the fan belts.
- **Smooth and Steady Operation:** Extended lube lines with grease fittings.

TAGS	QTY	MODEL	HP	RPM	ELECTRICAL	STATIC PRESSURE	AIRFLOW

ADDITIONAL OPTIONS

- Belt Guard
- Motor Cover
- Access Door
- Inlet / Outlet Guard
- Companion Flanges
- Special Coatings
- Vibration Isolators
- Mounting Brackets

NOTE: Romla Fans is committed to product improvement and retains the right to change specifications and dimensions at will without prior notification.