

MODEL TD OVERVIEW

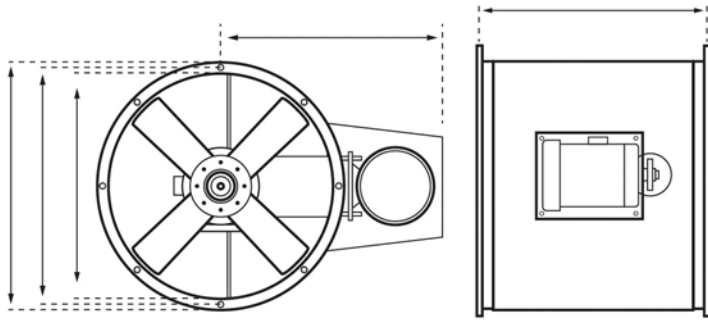

Project Number:
Project Name:
Customer:
Date:

Product Information

Fan: T Series
Drive: Direct Drive
Motor(s)

FAN SIZE	DIMENSIONS (INCHES)					APPROX. WT. (lbs.)
	A	B	C	L	H	
24	27-3/16	25 7/8	24	22	7/16	165
30	34 3/16	32 3/8	30	24	7/16	200
36	40 3/16	38 3/8	36	26	7/16	270
42	46 3/16	44 3/8	42	32	7/16	450
48	52 3/16	50 3/8	48	36	7/16	675

STANDARD FEATURES

- **Superior Strength Housing:** Heavy gauge all-welded housing with steel angle end flange rings.
- **Variable Pitch Drives to 7-1/2 HP:** Adjustable for systems RPM. Belts sized for 165% driven HP.
- **Industrial Duty Motor for Years of Trouble Free-Operation:** Totally enclosed fan cooled (TEFC) motor.
- **Self-Aligning Pillow Block Bearings**

TAGS	QTY	MODEL	HP	RPM	ELECTRICAL	STATIC PRESSURE	AIRFLOW

ADDITIONAL OPTIONS

- Access Door
- Inlet / Outlet Guard
- Companion Flanges
- Special Coatings
- Vibration Isolators
- Mounting Brackets

NOTE: Romla Fans is committed to product improvement and retains the right to change specifications and dimensions at will without prior notification.